

# MCH – 204: Spectroscopy-II & Diffraction Methods

## UNIT-III: X-ray Diffraction-I

### Lecture 1:

# The Generation of X-Rays, Xray tubes, Rotating Anodes, Synchrotron sources

Prof. Sushil Kumar Gupta  
School of Studies in Chemistry  
Jiwaji University Gwalior (M.P.)

# A bit of History

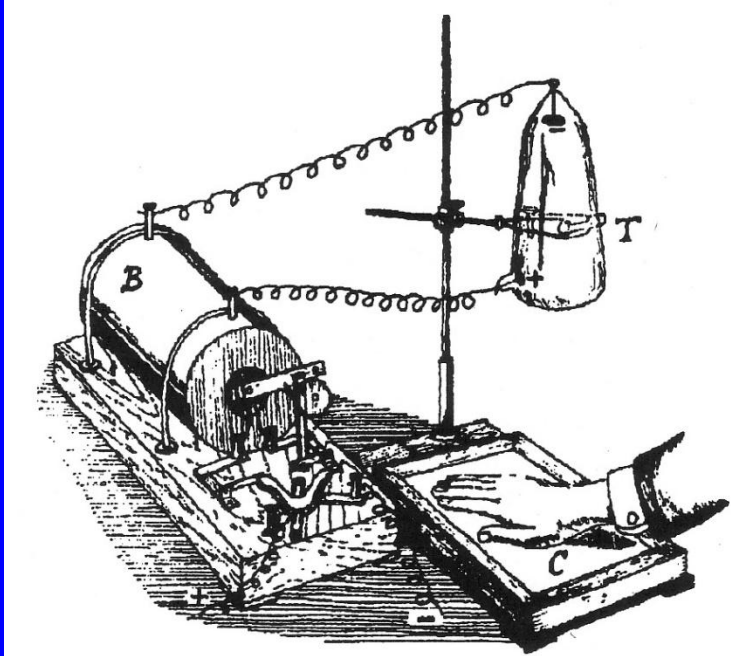
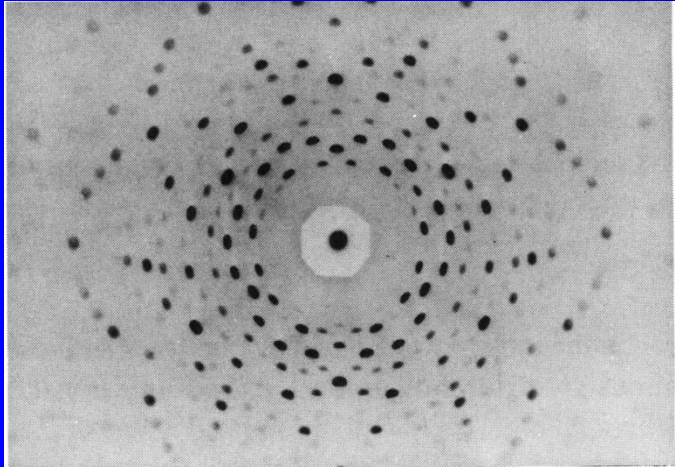

Fig. 1.1. Röntgen's experimental apparatus in 1895: B, Ruhmkorff induction coil; C, photographic plate; T, Hittorf-Crookes evacuated tube.

- **William Roentgen discovered X-rays in 1895 and determined they had the following properties**
  1. Travel in straight lines
  2. Are exponentially absorbed in matter with the exponent proportional to the mass of the absorbing material
  3. Darken photographic plates
  4. Make shadows of absorbing material on photosensitive paper
- **Roentgen was awarded the Nobel Prize in 1901**
- **Debate over the wave vs. particle nature of X-rays led the development of relativity and quantum mechanics**

# Discovery of Diffraction



- **The image created showed:**

1. The lattice of the crystal produced a series of regular spots from concentration of the x-ray intensity as it passed through the crystal and
2. Demonstrated the wave character of the x-rays
3. Proved that x-rays could be diffracted by crystalline materials

- Max von Laue theorized that if X-rays were waves, the wavelengths must be extremely small (on the order of  $10^{-10}$  meters)
- If true, the regular structure of crystalline materials should be “viewable” using X-rays
- His experiment used an X-ray source directed into a lead box containing an oriented crystal with a photographic plate behind the box

**Von Laue's results were published in 1912**

# Bragg's "Extensions" of Diffraction

- Lawrence Bragg and his father W.H. Bragg discovered that diffraction could be treated as reflection from evenly spaced planes if monochromatic x-radiation was used
- Bragg's Law:  $n\lambda = 2d \sin\theta$   
where  $n$  is an integer  
 $\lambda$  is the wavelength of the X-radiation  
 $d$  is the interplanar spacing in the crystalline material and  
 $\theta$  is the diffraction angle
- The Bragg Law makes X-ray single crystal and powder diffraction possible

# Notes on Units of Measure

- an angstrom ( $\text{\AA}$ ) is  $10^{-10}$  meters
- a nanometer (nm) is  $10^{-9}$  meters
- a micrometer ( $\mu\text{m}$ ) or micron is  $10^{-6}$  meters
- a millimeter (mm) is  $10^{-3}$  meters

In X-ray crystallography, d-spacings and X-ray wavelengths are commonly given in angstroms

# An ICDD Data "Card"

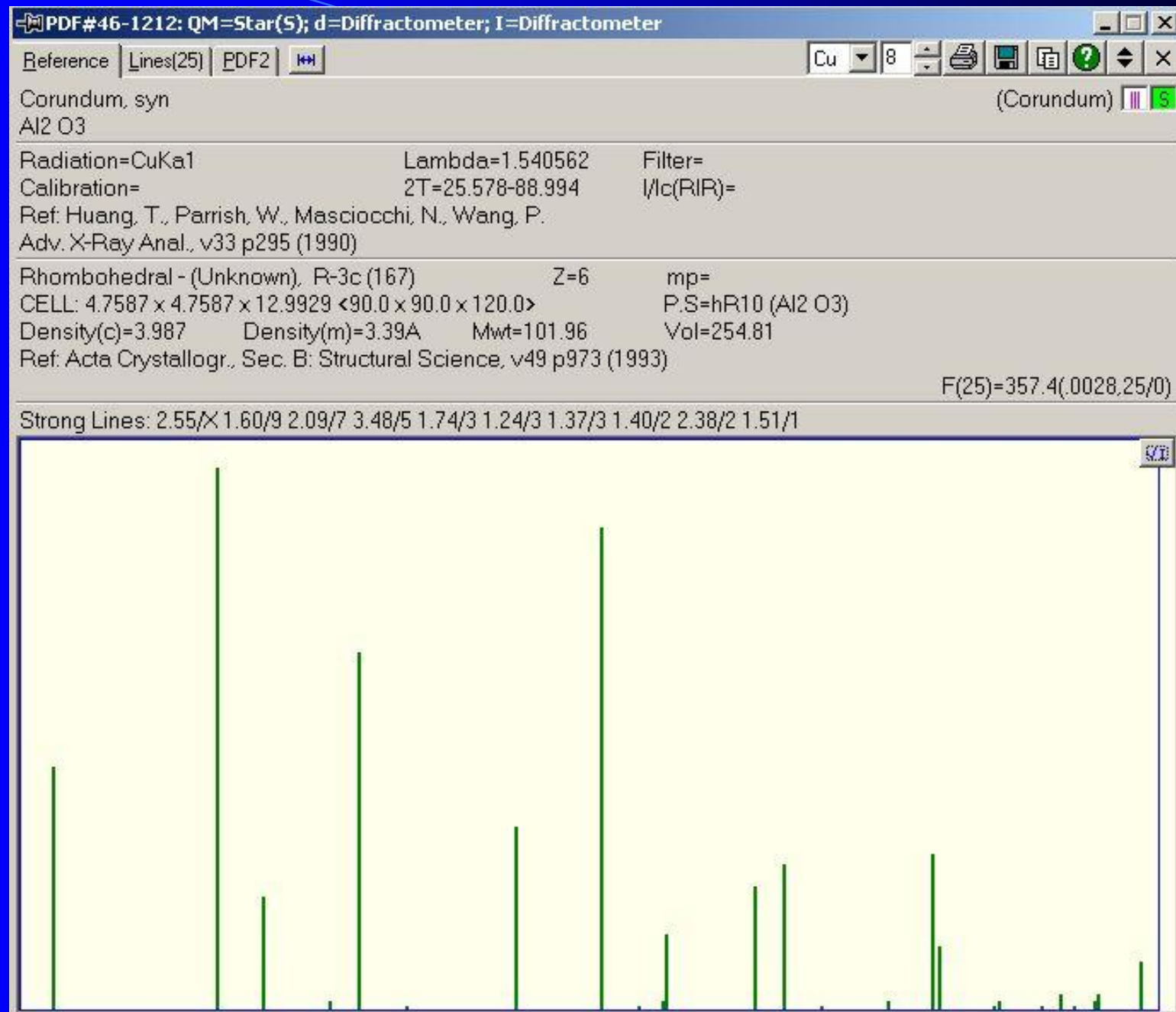

PDF#46-1212: QM=Star(S); d=Diffraction; l=Diffraction

Corundum, syn

Al<sub>2</sub>O<sub>3</sub>

Radiation=CuKα1

Lambda=1.540562

Filter=

Calibration= 2T=25.578-88.994

l/lc(RIR)=

Ref: Huang, T., Parrish, W., Masciocchi, N., Wang, P.

Adv. X-Ray Anal., v33 p295 (1990)

Rhombohedral - (Unknown), R-3c (167)

Z=6

mp=

CELL: 4.7587 x 4.7587 x 12.9929 <90.0 x 90.0 x 120.0>

P.S.=hR10 (Al<sub>2</sub>O<sub>3</sub>)

Density(c)=3.987

Density(m)=3.39A

Mwt=101.96

Vol=254.81

F(25)=357.4(.0028,25/0)

Ref: Acta Crystallogr., Sec. B: Structural Science, v49 p973 (1993)

Strong Lines: 2.55/X 1.60/9 2.09/7 3.48/5 1.74/3 1.24/3 1.37/3 1.40/2 2.38/2 1.51/1

NOTE: The sample is an alumina plate as received from ICDD.

Unit cell computed from dobs.

2-Theta	d(Å)	I(f)	(h k l)	Theta	1/(2d)	2pi/d	n <sup>2</sup>
25.578	3.4797	45.0	(0 1 2)	12.789	0.1437	1.8056	
35.152	2.5508	100.0	(1 0 4)	17.576	0.1960	2.4632	
37.776	2.3795	21.0	(1 1 0)	18.888	0.2101	2.6406	
41.675	2.1654	2.0	(0 0 6)	20.837	0.2309	0.2309	2.9016
43.355	2.0853	66.0	(1 1 3)	21.678	0.2398	3.0131	
46.175	1.9643	1.0	(2 0 2)	23.087	0.2545	0.2545	3.1987
52.549	1.7401	34.0	(0 2 4)	26.274	0.2873	3.6109	
57.496	1.6016	89.0	(1 1 6)	28.748	0.3122	3.9232	
59.739	1.5467	1.0	(2 1 1)	29.869	0.3233	0.3233	4.0624
61.117	1.5151	2.0	(1 2 2)	30.558	0.3300	0.3300	4.1472
61.298	1.5110	14.0	(0 1 8)	30.649	0.3309	4.1583	
66.519	1.4045	23.0	(2 1 4)	33.259	0.3560	4.4735	
68.212	1.3737	27.0	(3 0 0)	34.106	0.3640	4.5738	
70.418	1.3360	1.0	(1 2 5)	35.209	0.3743	0.3743	4.7030
74.297	1.2756	2.0	(2 0 8)	37.148	0.3920	0.3920	4.9259
76.869	1.2392	29.0	(1 0 10)	38.435	0.4035	5.0706	
77.224	1.2343	12.0	(1 1 9)	38.612	0.4051	5.0903	
80.419	1.1932	1.0	(2 1 7)	40.210	0.4191	0.4191	5.2660
80.698	1.1897	2.0	(2 2 0)	40.349	0.4203	0.4203	5.2812
83.215	1.1600	1.0	(3 0 6)	41.607	0.4310	0.4310	5.4164
84.356	1.1472	3.0	(2 2 3)	42.178	0.4358	0.4358	5.4769
85.140	1.1386	<1	(1 3 1)	42.570	0.4391	0.4391	5.5181
86.360	1.1257	2.0	(3 1 2)	43.180	0.4442	0.4442	5.5818
86.501	1.1242	3.0	(1 2 8)	43.250	0.4448	0.4448	5.5891
88.994	1.0990	9.0	(0 2 10)	44.497	0.4549	0.4549	5.7170

# The Electromagnetic Spectrum

## THE ELECTROMAGNETIC SPECTRUM

Cu-K $\alpha$

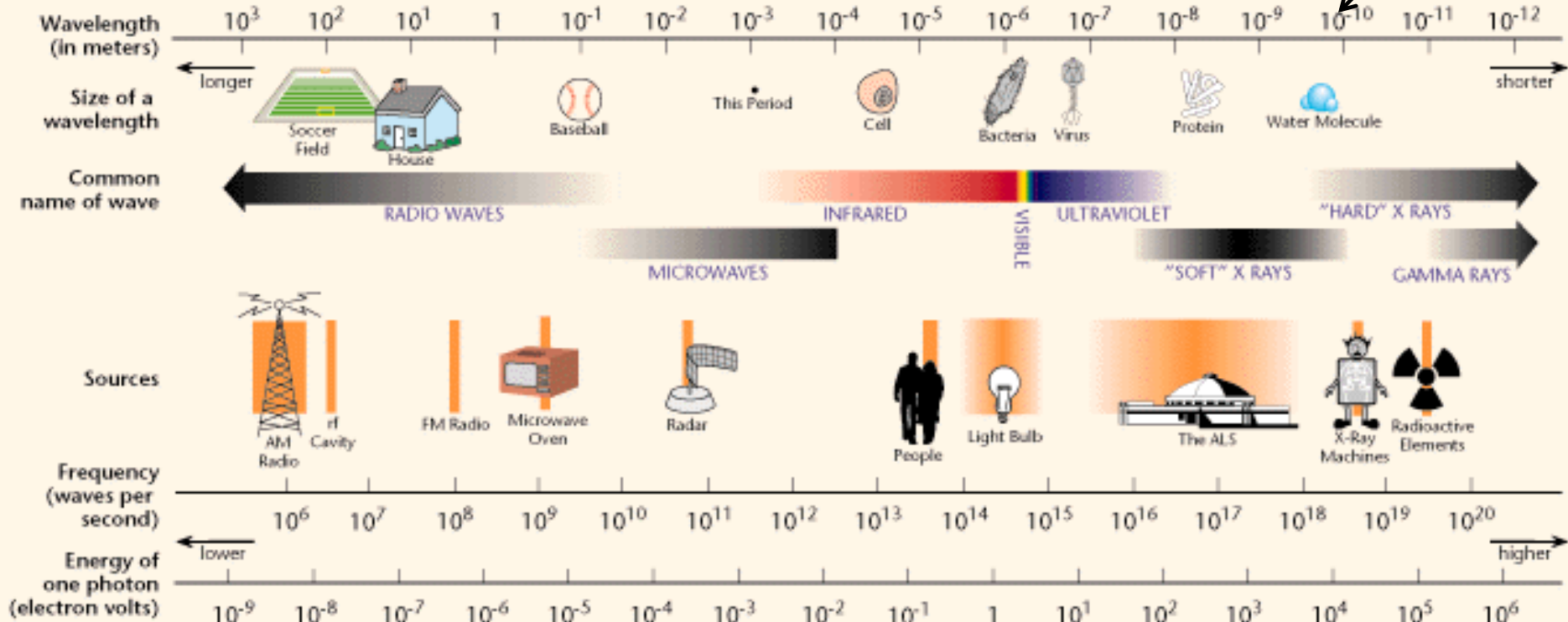



# Generating X-rays for Diffraction

- To get an accurate picture of the structure of a crystalline material requires X-radiation that is as close to monochromatic as possible.
- The function of the x-ray tube and associated electronics is to produce a limited frequency range of high-intensity x-rays.
- Filters, monochromators, specially tuned detectors and software are then used to further refine the frequency used in the analysis.

# The X-ray Tube

- Schematic cross section of an typical X-ray tube
- The anode is a pure metal. Cu, Mo, Fe, Co and Cr are in common use in XRD applications.
- The tube is cooled by water and housed in a shielding aluminum tower

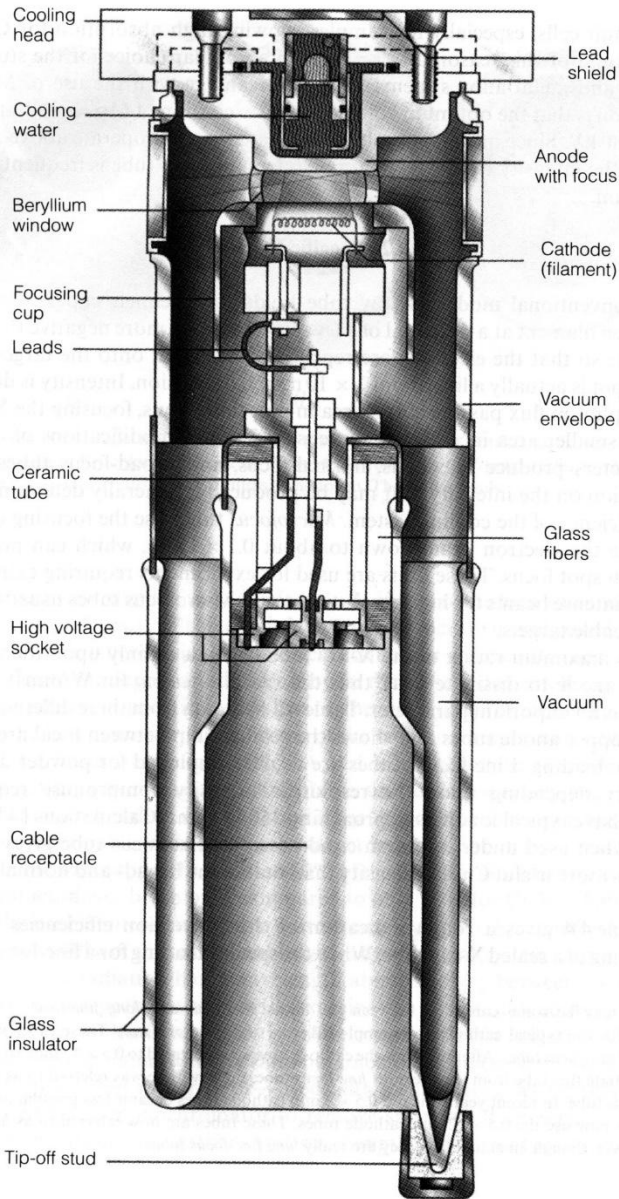

(a)

# Actual X-ray tubes

- Chilled water sprayed through the slit onto the back of the anode surface.
- Most X-ray tubes have a small filter to prevent small particles in the water supply damaging the rear of the anode

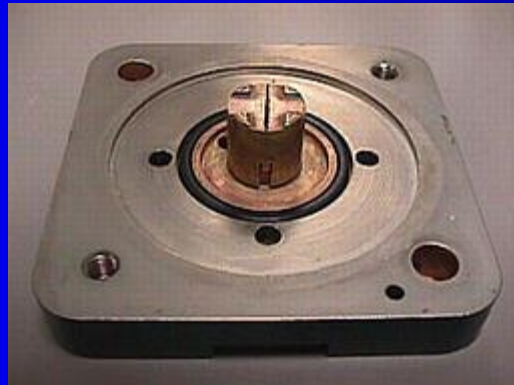

# X-rays Tube Schematic

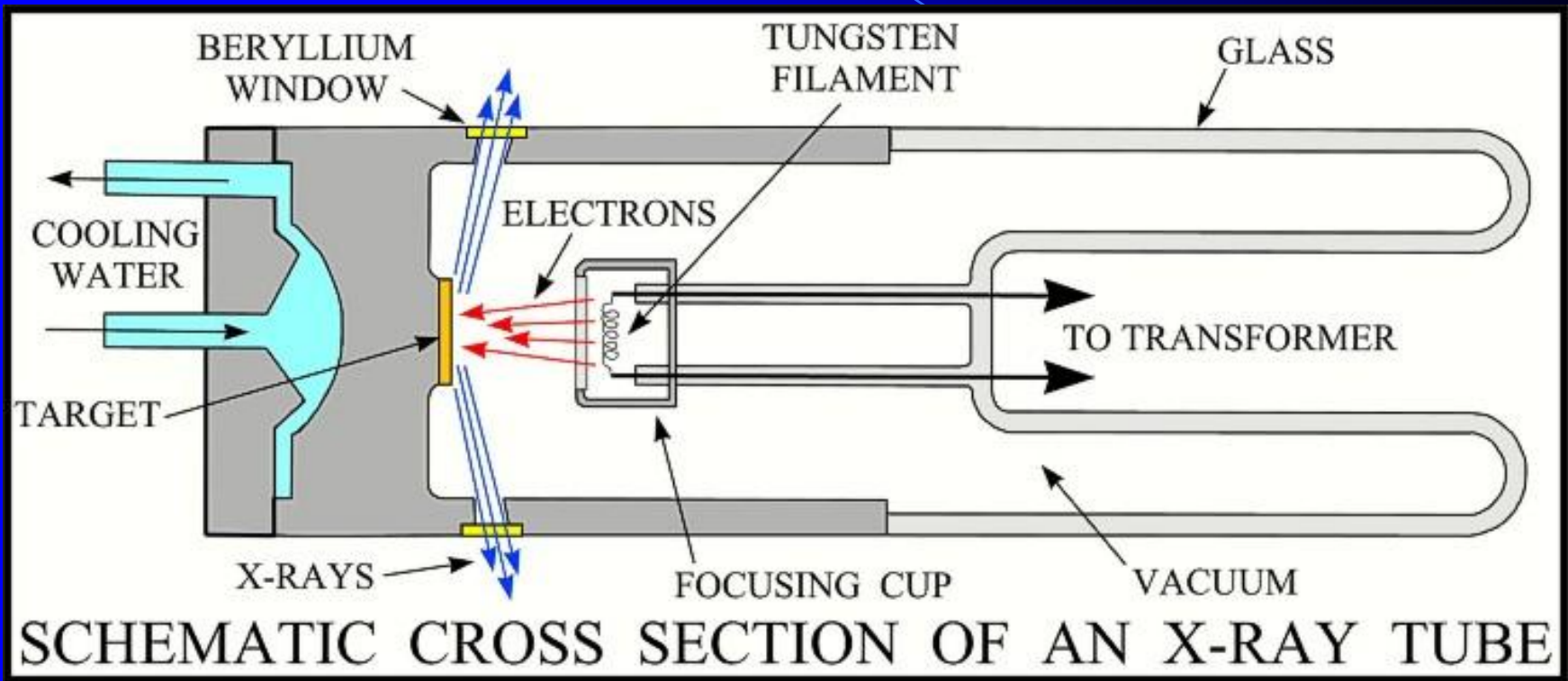

# X-ray generation

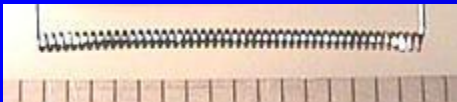
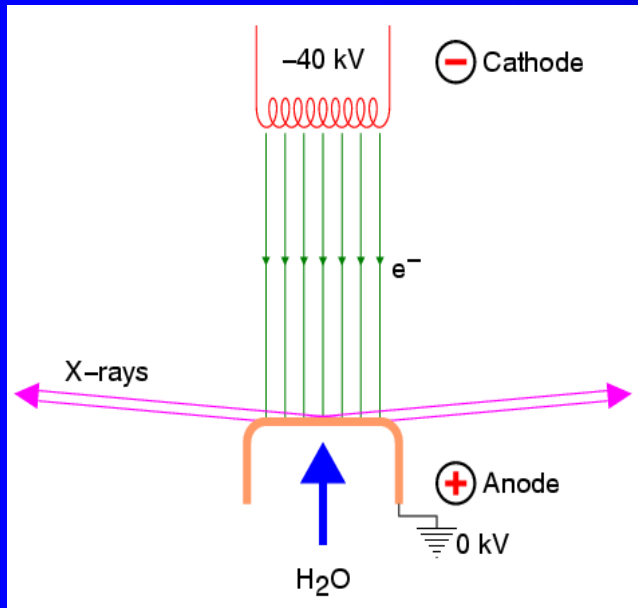

Key aspects behind the operation of the X-ray tube.

Heat load on the anode is of the order of kilowatts.

Most of the energy of the electrons hitting the anode target is dissipated as heat and so the tube is water cooled.

X-rays are generated in all directions, but the optimum angle for viewing the source is typically at about  $6^\circ$  to the anode surface.

Spot focus v line focus.

# Rotating anode generators

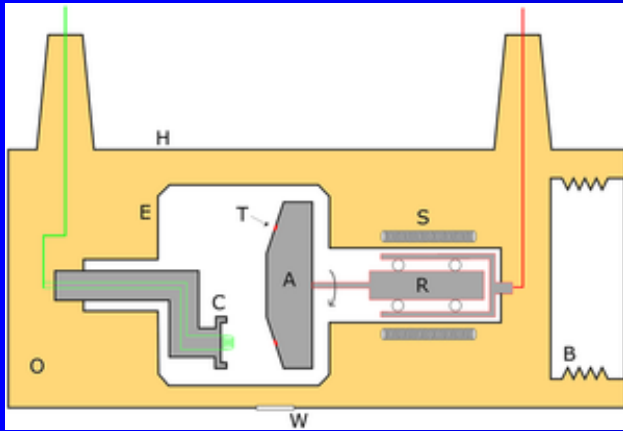

The anode is supported on vacuum or magnetic bearings.

Anode is rotated at high speed to dissipate the heat load.

Simplified rotating anode tube schematic

A: Anode

C: cathode

T: Anode target

W: X-ray window

Output between 10 – 20 kW compared to 2 – 3 kW for sealed tube.

Major disadvantages are high maintenance costs as bearings have to be changed every year and filament every 3 – 4 months

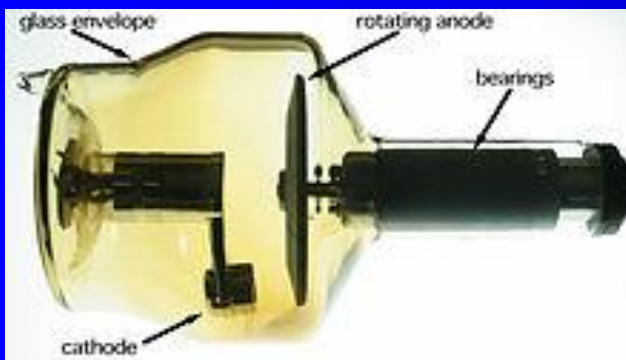

# Synchrotron sources

A synchrotron produces light by using radio frequency waves and powerful electro-magnets to accelerate electrons to nearly the speed of light. Energy is added to the electrons as they accelerate so that, when the magnets alter their course, they naturally emit a very brilliant, highly focused light. Different spectra of light, such as Infrared, Ultraviolet, and X-rays, are directed down beamlines where researchers choose the desired wavelength to study their samples. The researchers observe the interaction between the light and matter in their sample at the endstations (small laboratories).

# How it works – Electron gun

## Electron Gun:

The process begins when high voltage electricity passing through a heated cathode produces pulses of electrons. Heating the cathode to incandescence gives some electrons enough energy to leave the surface (essentially boils them off). The high voltage repels the electrons, accelerating them toward the Linear Accelerator, or LINAC.





# How it works – Linear Accelerator



The electron gun supplies electrons to the Linear Accelerator (LINAC). A series of cavities with microwave radio frequency fields in the 2,856 megahertz LINAC provide energy to the electrons that are accelerated to an energy of 250 million electron volts, or 250 MeV. At this energy the electrons are travelling at 99.9998% of the speed of light ( $3.0 \times 10^8$  m/s).

# How it works – Booster ring

The electrons must travel in a vacuum to avoid colliding into atoms or molecules and disappearing. The ultimate vacuum chamber pressure is lower than  $10^{-11}$  torr. This means that there are fewer molecules present in our vacuum system than there are in space around the International Space Station.

Electrons travel from the LINAC to the Booster Ring where a specially designed radio frequency cavity raises the energy of the electrons from 250 MeV to 2900 MeV as they circulate in the ring. Following this boost in energy, the electrons are transferred to the Storage Ring.



# How it works – Storage ring

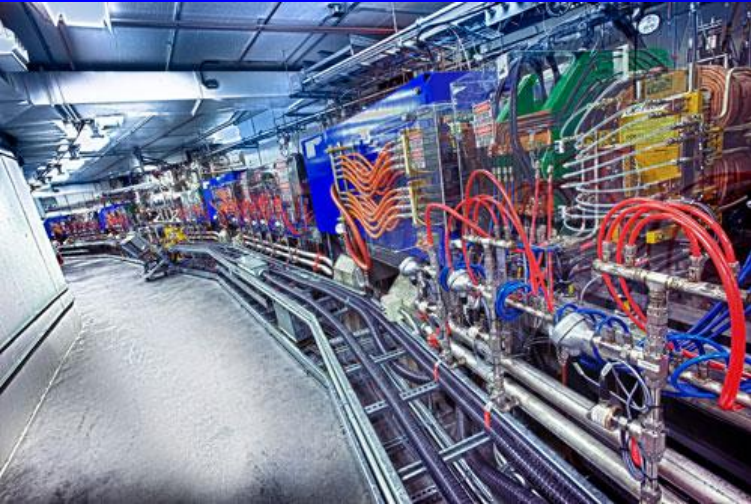

The high energy electrons are transferred from the Booster Ring, to circulate the Storage Ring's twelve straight sections. The electrons emit synchrotron light every time their path is bent by the magnets inside the Storage Ring. In each straight section there are also special magnets series called Insertion Devices that increase the brightness of the beam before entering the Beamline.

# How it works - Bending magnets, wigglers & undulators

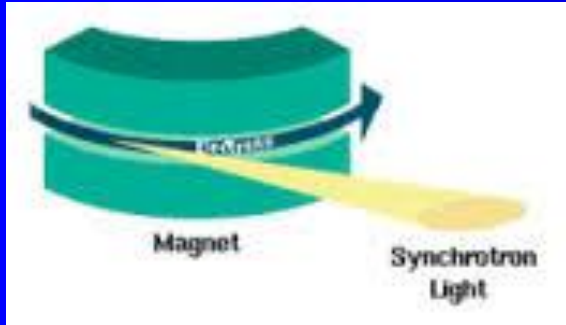

Bending magnets change the direction of the beam of electrons causing radiation to be emitted.

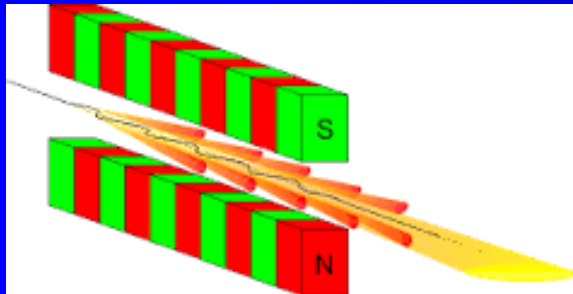

Wigglers give a more intense beam of synchrotron radiation.

Undulators also give an intense beam of synchrotron radiation but over a narrower spectral range

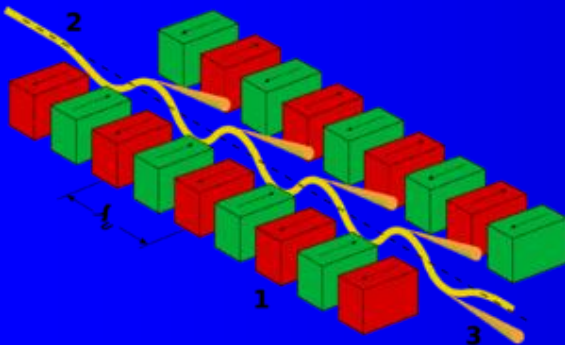

# How it works – Experimental stations

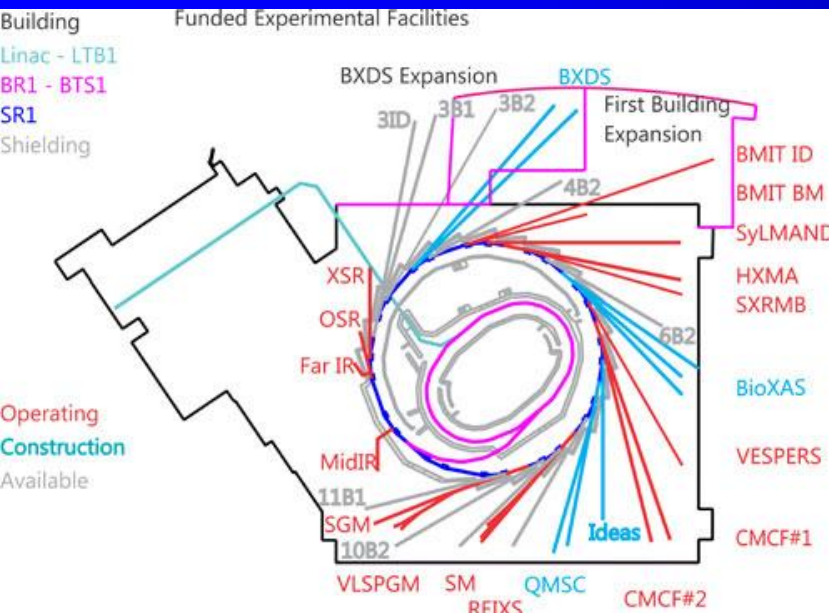

A beamline has several major components including sections that focus and select the required wavelength of light, select the appropriate technique for the experiment, and detect or measure effects of the light as it interacts with the sample.

# How it works - Beamstations

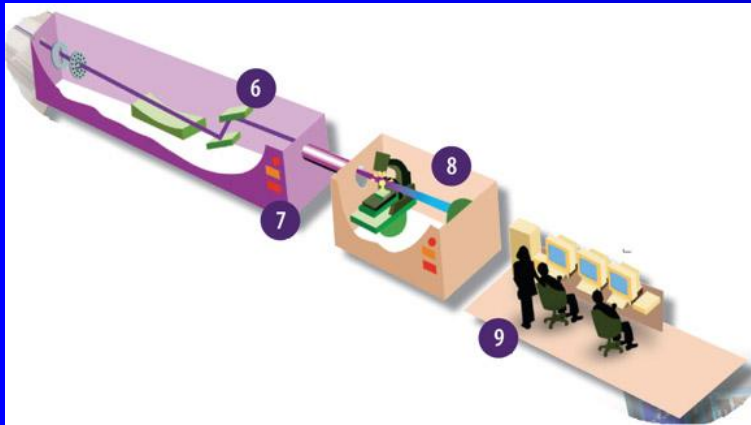

A beamline (#6 above) consists of an optics hutch (#7) where synchrotron light is focused and wavelength is selected, an experimentation hutch (#8) where the appropriate technique is selected for the experiment, and work stations (#9) where scientists operate the beamline and measure light as it is absorbed, reflected, refracted, or scattered by the sample.

# Characteristics of Common Anode Materials

Material	At. #	$K\alpha_1$ (Å)	$K\alpha_2$ (Å)	Char Min (keV)	Opt kV	Advantages (Disadvantages)
Cr	24	2.290	2.294	5.98	40	High resolution for large d-spacings, particularly organics (High attenuation in air)
Fe	26	1.936	1.940	7.10	40	Most useful for Fe-rich materials where Fe fluorescence is a problem (Strongly fluoresces Cr in specimens)
Co	27	1.789	1.793	7.71	40	Useful for Fe-rich materials where Fe fluorescence is a problem
Cu	29	1.541	1.544	8.86	45	Best overall for most organic materials and large cells (Fluoresces Fe and Co $K\alpha$ and large absorption for heavy atoms)
Mo	42	0.709	0.714	20.00	80	Short wavelength good for small to intermediate unit cells, particularly inorganic samples and samples containing heavy elements (Poor resolution of large d-spacings)

# Generation of X-rays

$$\nu = \frac{c}{\lambda} \quad (1)$$

$$E = h\nu \quad (2)$$

$$E = \frac{hc}{\lambda} \quad (3)$$

$$E = \frac{12.398}{\lambda} \quad (4)$$

- X-rays may be described as waves and particles, having both wavelength ( $\lambda$ ) and energy ( $E$ )
- In the equations at left:
  - $E$  is the energy of the electron flux in KeV
  - $h$  is Planck's constant ( $4.135 \times 10^{-15}$  eVs)
  - $\nu$  is the frequency
  - $c$  is the speed of light ( $3 \times 10^{18}$  Å/s)
  - $\lambda$  is the wavelength in Å
- Substituting (1) into (2) yields (3), the relationship between wavelength and energy.
- In (4) all constants are substituted



# Continuous Spectrum

- X-rays are produced whenever matter is irradiated with a beam of high-energy charged particles or photons
- In an x-ray tube, the interactions are between the electrons and the target. Since energy must be conserved, the energy loss from the interaction results in the release of x-ray photons
- The energy (wavelength) will be equal to the energy loss (Equation 4).
- This process generates a broad band of continuous radiation (a.k.a. bremsstrahlung or white radiation)

# Continuous Spectrum

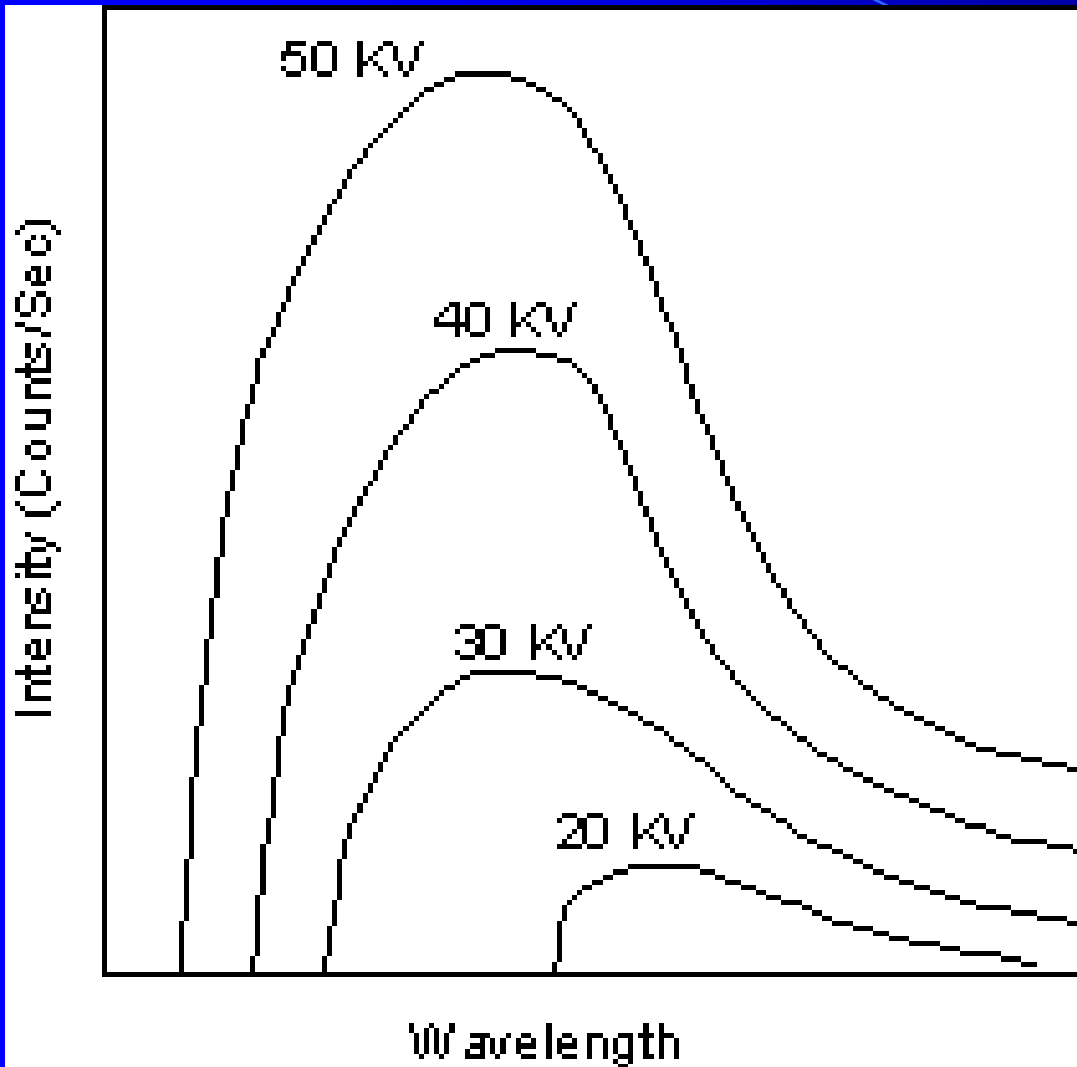

$$\lambda_{\min} = \frac{hc}{V} = \frac{12.398}{V}$$

- The minimum wavelength ( $\lambda$  in angstroms) is dependent on the accelerating potential ( $v$  in KV) of the electrons, by the equation above.
- The continuum reaches a maximum intensity at a wavelength of about 1.5 to 2 times the  $\lambda_{\min}$  as indicated by the shape of the curve

# Generating Characteristic Radiation

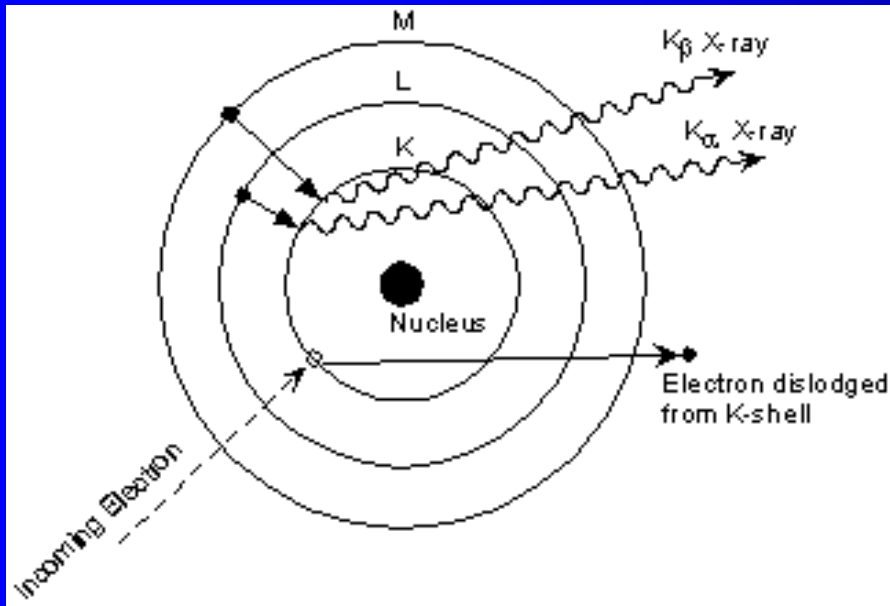

**L-shell to K-shell jump  
produces a  $K_{\alpha}$  x-ray**  
**M-shell to K-shell jump  
produces a  $K_{\beta}$  x-ray**

- The photoelectric effect is responsible for generation of characteristic x-rays. Qualitatively here's what is happening:

- An incoming high-energy photoelectron dislodges a k-shell electron in the target, leaving a vacancy in the shell
- An outer shell electron then “jumps” to fill the vacancy
- A characteristic x-ray (equivalent to the energy change in the “jump”) is generated

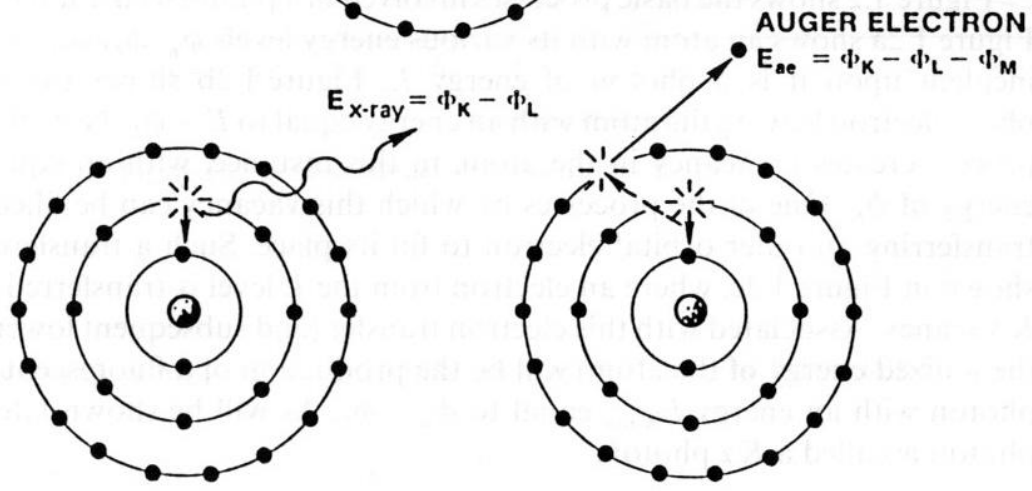
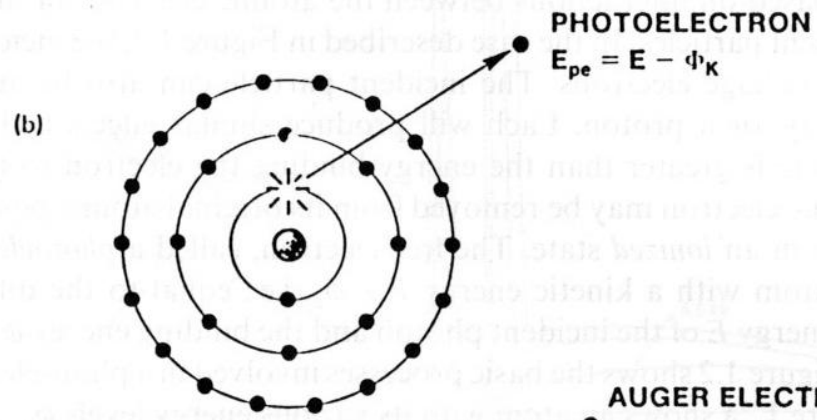
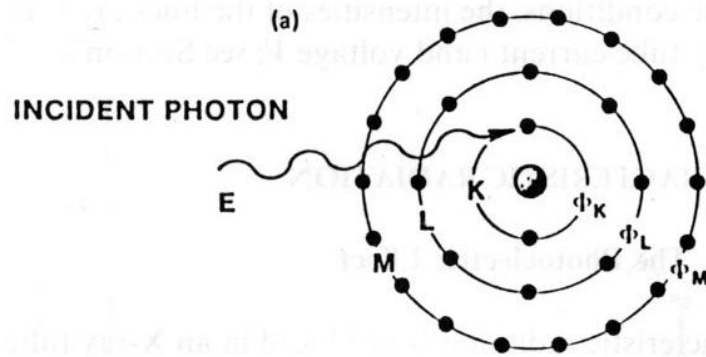

(c) OR (d)

# The Copper K Spectrum

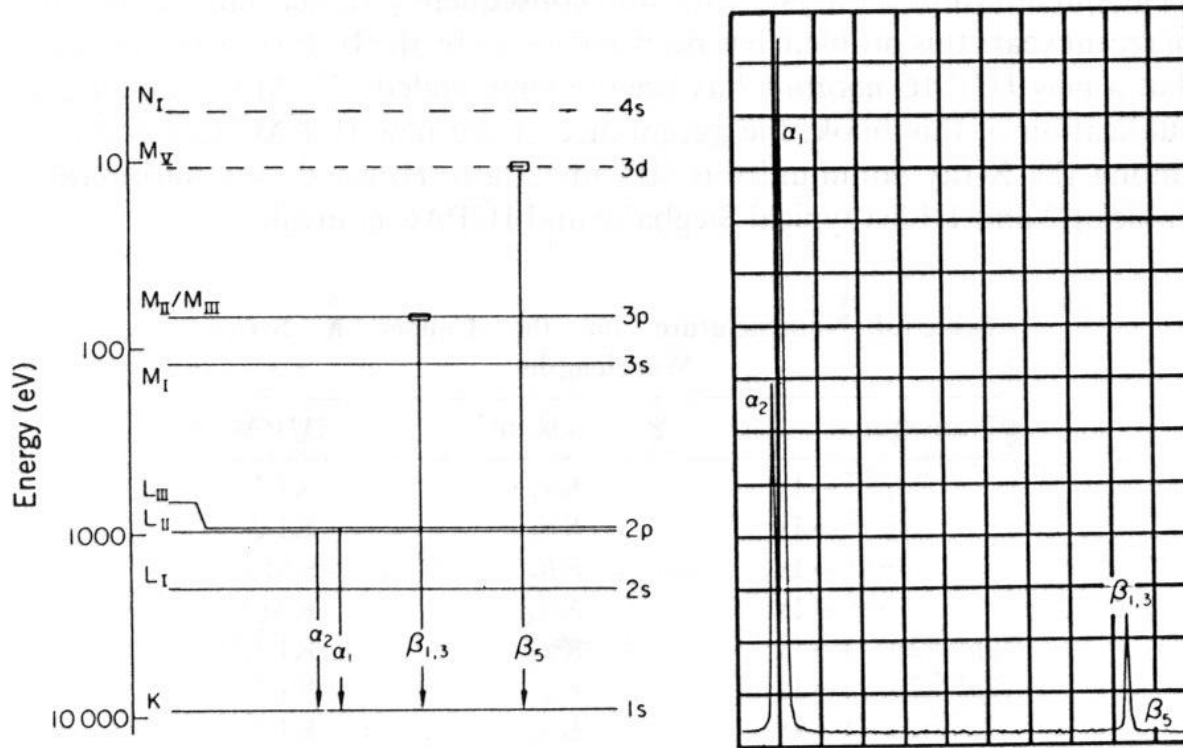

The copper  $K\alpha$  spectrum.

- The diagram at left shows the 5 possible Cu K transitions
- L to K “jumps:
  - $K\alpha_1$  (8.045 keV, 1.5406Å)
  - $K\alpha_2$  (8.025 keV, 1.5444Å)
- M to K
  - $K\beta_1$   $K\beta_3$  (8.903 keV, 1.3922Å)
  - $K\beta_5$

Note: The energy of the  $K\beta$  transitions is higher than that of the  $K\alpha$  transitions, but because they are much less frequent, intensity is lower

# Continuous and Characteristic Spectrum

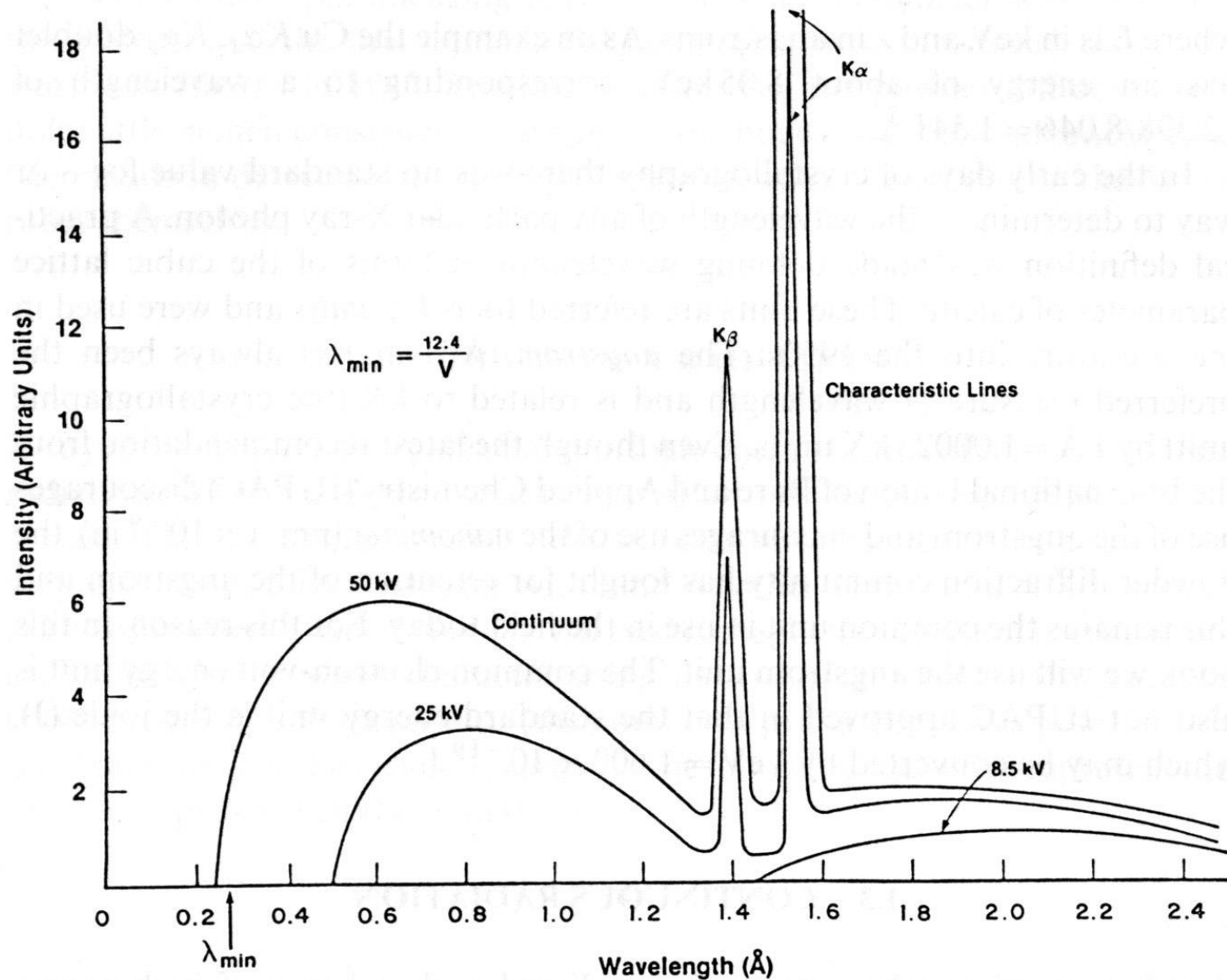

Continuous and characteristic radiation for copper.

# Characteristic Wavelength values (in Å) for Common Anode Materials

<b>Anode</b>	<b><math>K\alpha_1</math> (100)</b>	<b><math>K\alpha_2</math> (50)</b>	<b><math>K\beta</math> (15)</b>
<b>Cu</b>	<b>1.54060</b>	<b>1.54439</b>	<b>1.39222</b>
<b>Cr</b>	<b>2.28970</b>	<b>2.29361</b>	<b>2.08487</b>
<b>Fe</b>	<b>1.93604</b>	<b>1.93998</b>	<b>1.75661</b>
<b>Co</b>	<b>1.78897</b>	<b>1.79285</b>	<b>1.62079</b>
<b>Mo</b>	<b>0.70930</b>	<b>0.71359</b>	<b>0.63229</b>

\* Relative intensities are shown in parentheses

# Making Monochromatic X-rays

- X-rays coming out of the tube will include the continuum, and the characteristic  $K\alpha_1$ ,  $K\alpha_2$ , and  $K\beta$  radiations
- A variety of methods may be used to convert this radiation into something effectively monochromatic for diffraction analysis:
  - Use of a  $\beta$  filter
  - Use of proportional detector and pulse height selection
  - Use of a Si(Li) solid-state detector
  - Use of a diffracted or primary beam monochromator



# $\beta$ Filters

- There are two types of absorption of x-rays.
  - **Mass absorption** is linear and dependent on mass
  - **Photoelectric absorption** is based on quantum interactions and will increase up to a particular wavelength, then drop abruptly
- By careful selection of the correct absorber, photoelectric absorption can be used to select a “filter” to remove most  $\beta$  radiation while “passing” most  $\alpha$  radiation

# $\beta$ Filters for Common Anodes

Target	$K\alpha$ (Å)	$\beta$ -filter	Thickness ( $\mu\text{m}$ )	Density (g/cc)	% $K\alpha$	% $K\beta$
Cr	2.291	V	11	6.00	58	3
Fe	1.937	Mn	11	7.43	59	3
Co	1.791	Fe	12	7.87	57	3
Cu	1.542	Ni	15	8.90	52	2
Mo	0.710	Zr	81	6.50	44	1

Note: Thickness is selected for max/min attenuation/transmission. Standard practice is to choose a filter thickness where the  $\alpha : \beta$  is between 25:1 and 50:1.

# Filtration of the Cu Spectrum by a Ni Filter

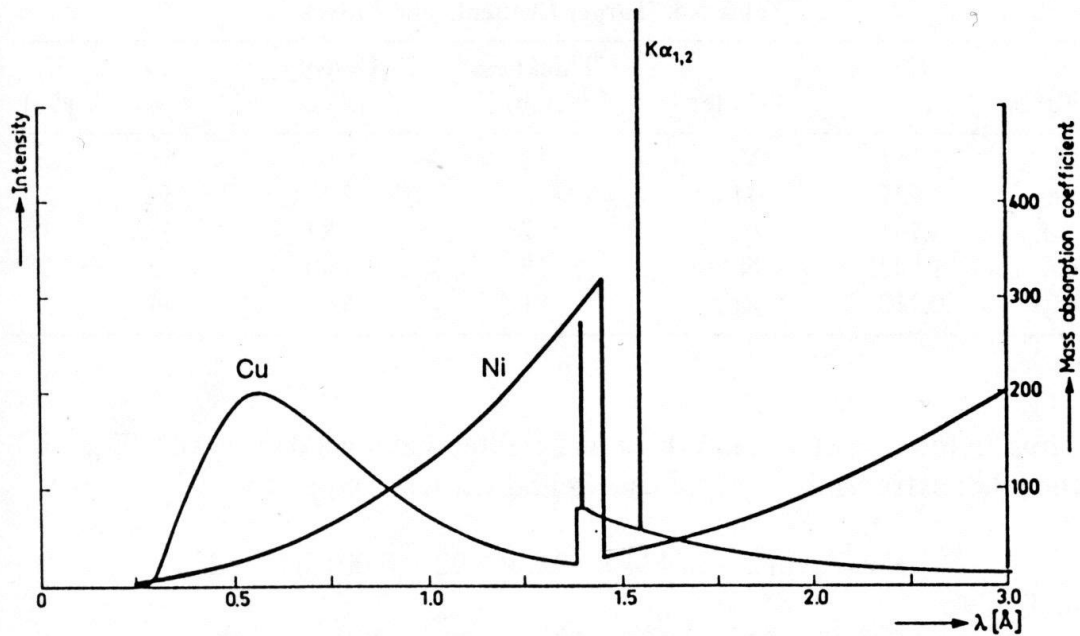

Use of the  $K\beta$ -filter. Reprinted from R. Jenkins and J. L. de Vries, *An Introduction to Powder Diffractometry*, p. 14, Fig. 12. Copyright © 1977, N. V. Philips, Eindhoven, The Netherlands.

## Filter Placement:

- In a diffractometer, the filter may be placed on the tube or detector side.
- In powder cameras (or systems with large 2D detectors), the filter will be between the tube and the camera (or specimen).

- The Ni absorption edge lies between the  $K\beta$  and  $K\alpha$  peaks
- Note the jump in the continuum to the left of the  $K\beta$  peak from Cu self-absorption
- Note that the Ni filter does little to remove the high-energy high-intensity portion of the continuum

# Discriminating with Detectors

- Pulse-height Discrimination
  - Detector electronics are set to limit the energy of x-rays seen by the detector to a threshold level
  - Effectively removes the most of the continuum and radiation produced by sample fluorescence
  - Particularly effective combined with a crystal monochromator
- “Tunable” Detectors
  - Modern solid state detectors, are capable of extremely good energy resolution
  - Can selectively “see” only  $K\alpha$  or  $K\beta$  energy
  - No other filtration is necessary, thus signal to noise ratios can be extremely high
  - Can negatively impact intensity of signal

# Monochromators

- Following the Bragg law, each component wavelength of a polychromatic beam of radiation directed at a single crystal of known orientation and d-spacing will be diffracted at a discrete angle
- Monochromators make use of this fact to selectively remove radiation outside of a tunable energy range, and pass only the radiation of interest
  - **A filter selectively attenuates  $K\beta$  and has limited effect on other wavelengths of X-rays**
  - **a monochromator selectively passes the desired wavelength and attenuates everything else.**
- Monochromators may be placed anywhere in the diffractometer signal path

# Pyrolytic graphite v silicon

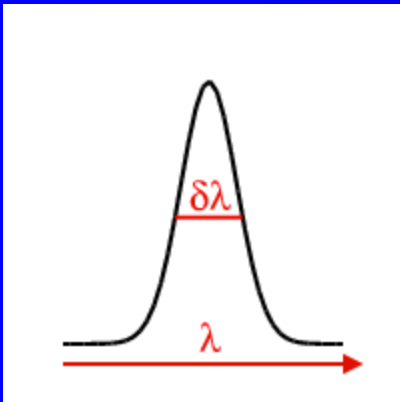
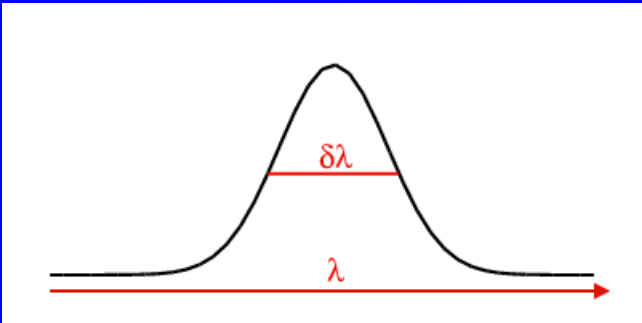

- Two commonly used materials are pyrolytic graphite and silicon, which can be used to make broad band and narrow band ( $\Delta\lambda / \lambda$ ) monochromators, respectively. For pyrolytic graphite, the mosaic spread is relatively broad in contrast to silicon in which the alignment of the mosaic blocks is near perfect.

# Monochromators

- The monochromator works by reflection of the wavelengths that obey Bragg's Law for the particular  $d$  spacings of the monochromator.
- For a silicon crystal (which is cubic with a unit cell size equal to  $5.4309 \text{ \AA}$ ), the largest  $d$  spacing (which is from the (111) planes) is  $3.136 \text{ \AA}$ .
- Application of the Bragg equation ( $\lambda = 2d \sin \theta$ ) shows that for Cu  $K\alpha_1$ , the diffraction condition will be satisfied for  $2\theta = 28.442^\circ$ , while for Cu  $K\alpha_2$ , it will be satisfied for  $2\theta = 28.514^\circ$ , giving a difference in Bragg angle of only  $0.072^\circ$ .
- Hence only monochromator crystals with a narrow band pass, e.g. silicon, will be able to separate the  $K\alpha_1$  and  $K\alpha_2$  wavelengths from a laboratory copper X-ray source.
- By contrast, pyrolytic graphite monochromators with their wide band pass will pass both  $K\alpha$  wavelengths, but not  $K\beta$  for which the Bragg angle is considerably different.
- In most real cases only separation of  $K\alpha$  and  $K\beta$  is required so graphite is used.

# Pyrolytic Graphite curved-crystal Monochromator

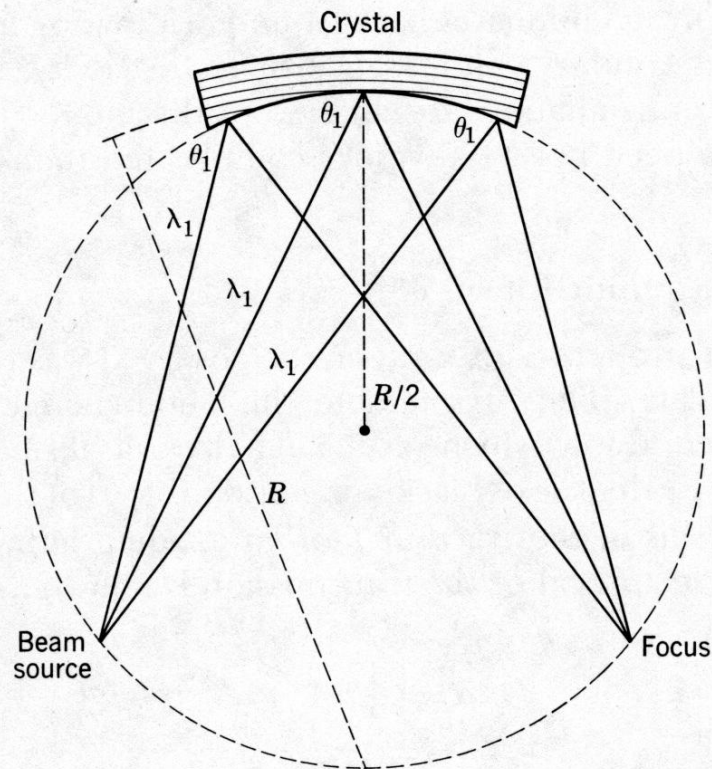

Accurate focusing by a bent-ground monochromatizing crystal.

- A planar crystal will diffract over a very small angular range and significantly reduce the intensity of the x-ray signal
- Precisely “bent” and machined synthetic crystals allow a divergent x-ray beam to be focused effectively with minimal signal loss

The pyrolytic graphite curved crystal monochromator is the most widely used type in XRD laboratories



# Graphite Monochromator on Scintag Diffractometer

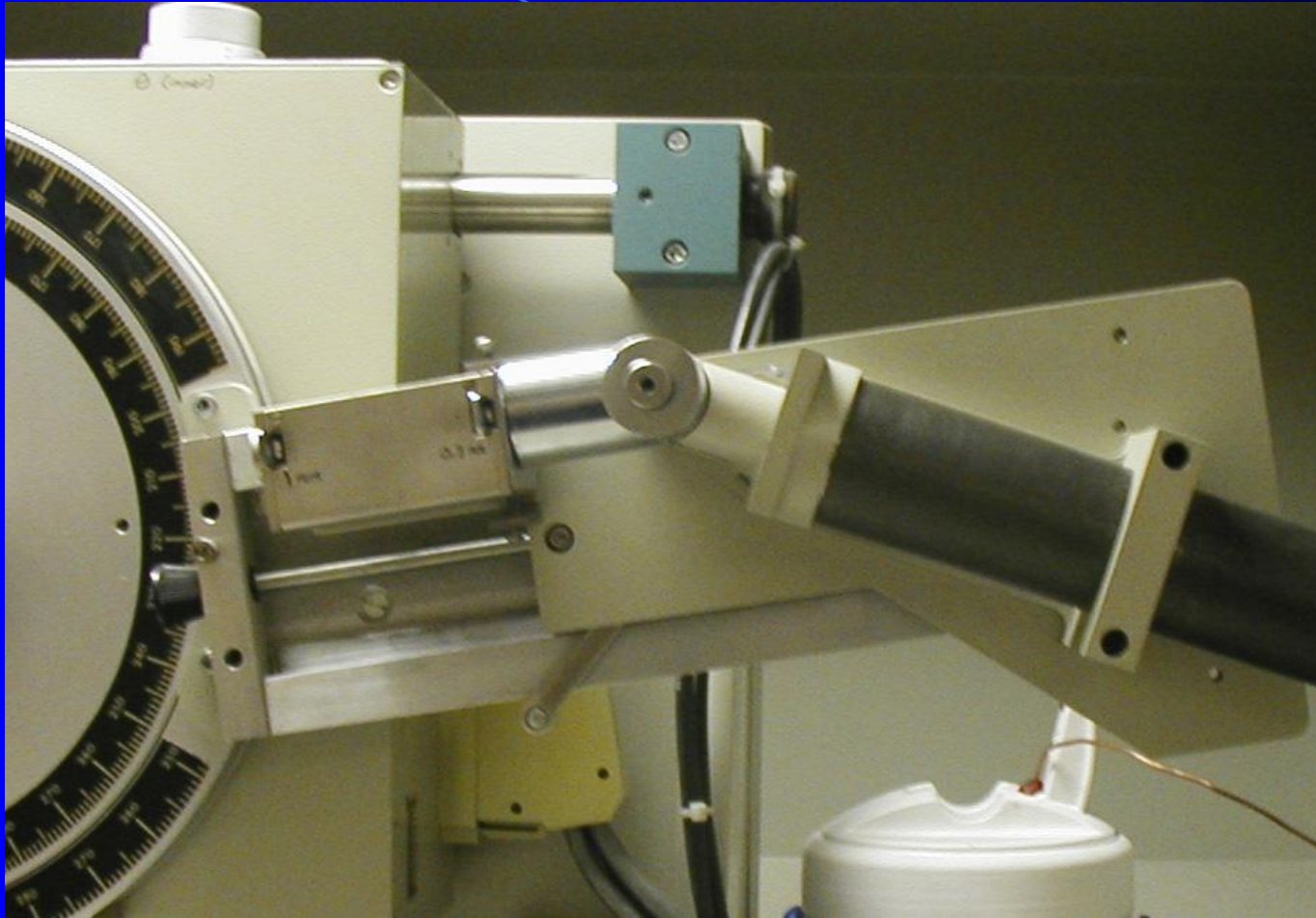

Diffracted-beam parallel geometry

From left: Receiving scatter slit, soller slit assembly, receiving slit, monochromator (path bends) and scintillation detector

# Summary

- A Ni filter will attenuate Cu  $K\beta$  radiation, but pass almost everything else (including high-energy portions of the background spectrum)

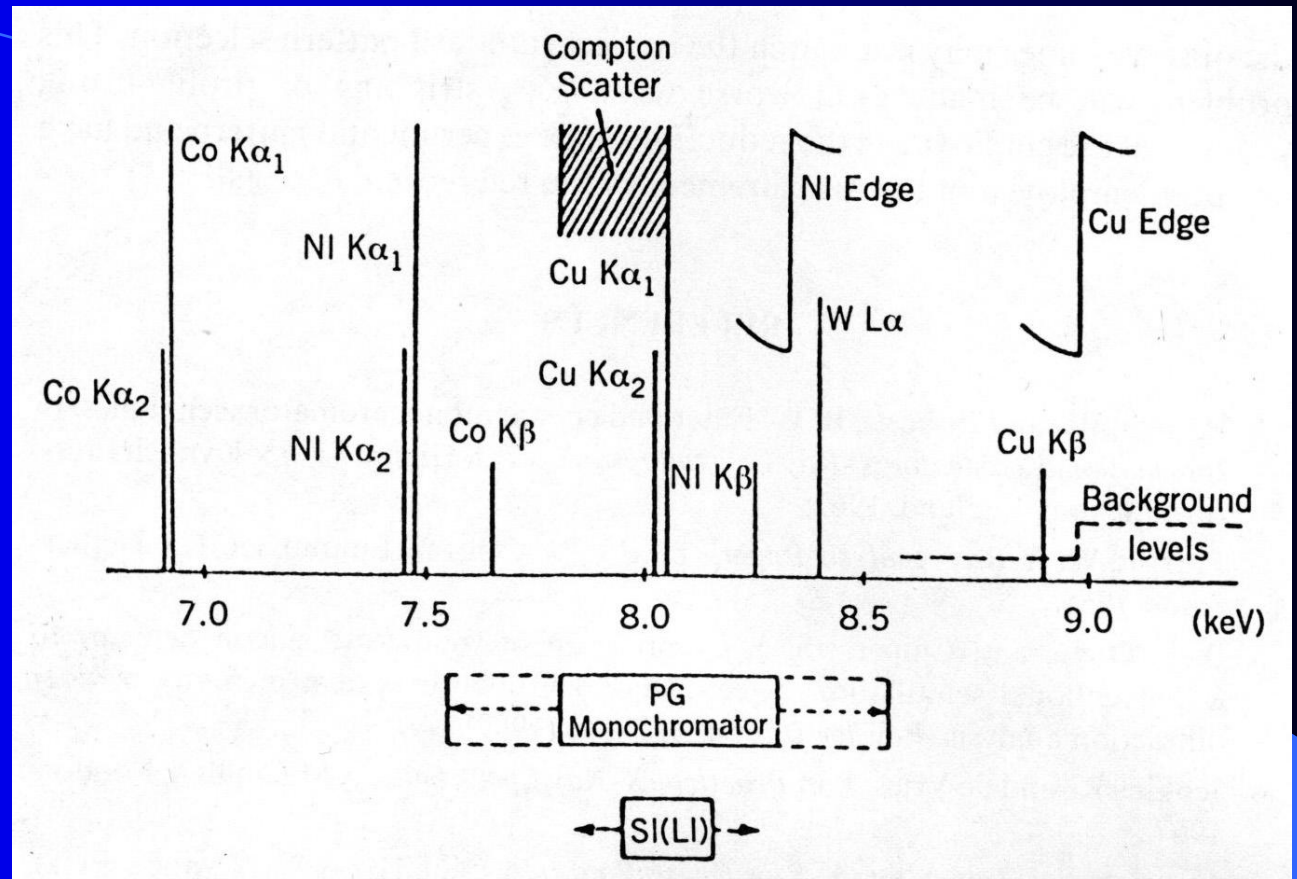

- A Si(Li) detector may be tuned to see only  $K\alpha$  radiation
- A graphite (PG) monochromator will select Cu  $K\alpha$ , but the acceptance windows will also admit a few other wavelengths. A tungsten (W)  $L\alpha$  line may be present as anode contamination in an “aged” Cu x-ray tube
- Compton scatter will always contribute something to the background